

PRECISION INSTRUMENT COMPANY

“115D” SERIES GAUGES

These 4 1/2 & 6 “ gauges have been designed and built primarily for the Industrial Market. They are well suited for all applications where bronze tube and socket are suitable for use. Some typical applications are; AIR, WATER, GAS, OIL and STEAM*

(* A pigtail / siphon should always be used when putting any gauge into steam service)

STANDARD FEATURES

- Heavy Duty Black Steel Case
(Epoxy Coated For Rust And Corrosion Resistance)
- Plastic Lens (To Resist Breakage)
- + / - 1% Full Scale Accuracy
- Large Easy To Read Numbers
(On Single Scale Psi Only Dial)
- Removable Back Flange
(For More Diversity From Stock)



Note: All Typical Accessory Type Items Such As Gauge Cock's, Pigtail/Siphones's, Snubbers, Needle Valves Or Diaphragm Seals Can Be Provided With Gauges Upon Request.

PART NUMBER		RANGE	MAJOR INC	MINOR INC
4 1/2”	6”			
115D-454A	115D-604A	30”HG VAC	5”hg	2”hg
115D-454CC	115D-604CC	30/0/30	5 psi	1 psi
115D-454CE	115D-604CE	30/0/100	10 psi	1 psi
115D-454CF	115D-604CF	30/0/160	25 psi	2.5 psi
115D-454B	115D-604B	0/15		
115D-454C	115D-604C	0/30	5 psi	1 psi
115D-454D	115D-604D	0/60	10 psi	1 psi
115D-454E	115D-604E	0/100	10 psi	1 psi
115D-454F	115D-604F	0/160	20 psi	2 psi
115D-454G	115D-604G	0/200	20 psi	2 psi
115D-454H	115D-604H	0/300	50 psi	5 psi
115D-454K	115D-604K	0/600	100 PSI	10 PSI

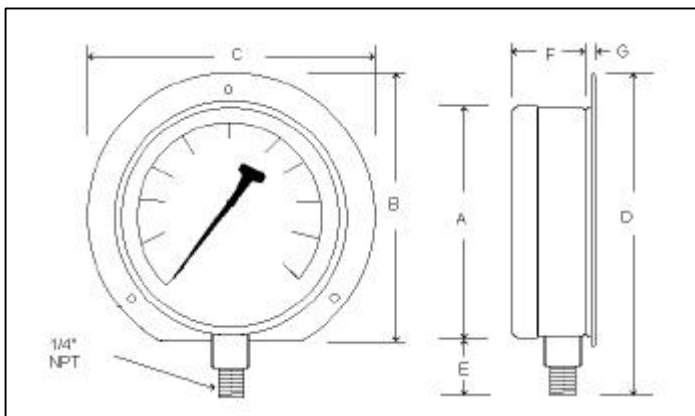

	4 1/2” Dial Size		6” Dial Size	
	In.	MM	In.	MM
A	4.99”	125	5.95”	151
B	5.41”	138	6.87”	175
C	5.87”	149	7.42”	188
D	6.79”	172	8.41”	213
E	1.40”	36	1.61”	41
F	1.86”	47	1.86”	47
G	.18”	4.5	.24”	6