

# PRECISION INSTRUMENT COMPANY

## MODEL '202L', LIQUID FILLED GAUGES

Our '200' Series Gauge Line Is A High Quality Line Of Liquid Filled Gauges. The Glycerine Filling and built in snubber Helps Dampen The Effects Of Pulsation And Vibration, While Also Perpetually Lubricating The Movement (And Keeping Contaminates Such As Dirt Away From All Moving Parts) Which Will Extend The Life Of The Gauge.

This Gauge Has Been Specifically Designed With The Original Equipment Manufacturers In Mind And Are Typically Used On Hydraulic & Pneumatic Systems As Well As Any Commercial Or Industrial Application Not Corrosive To Brass And Bronze Wetted Parts Where Glycerine Filling Is Suitable For Use.

### SPECIFICATIONS:

- **Available Dial Sizes:** 1 ½, 2", 2 ½, 3 ½, 4"
- **Available Connection Sizes:** (includes built-in snubber)  
1/8" MNPT on 1 ½ and 2"  
1/4" MNPT on 2", 2 ½, 3 ½ and 4"
- **Stainless Steel Case And Bezel**
- **Brass Internals & Connection**
- **Phosphour Bronze Bourdon Tube**
- **Liquid Filled (Dry Available)**
- **Accuracy :** 1 ½ and 2" Dial = 2 %  
2 ½ Dial Size = 1.5 %  
3 ½ and 4" Dial Size = 1 %
- **Dual Scale: PSI & Bar (x100=kPa)**  
Single Scale available from stock
- **Ambient temperature:** FILLED: 30°F to 160°F  
DRY: -30°F to 180°F



RANGE	CODE	Major In	Minor In
30/0"VAC	A	5	0.5
30/0/15	CB	5	0.5
30/0/30	CC	10	1
30/0/60	CD	10	1
30/0/100	CE	20	2
30/0/150	CF	20	2
30/0/300	CH	50	10
0/15	B	2	0.2
0/30	C	5	0.5
0/60	D	10	1
0/100	E	20	2
0/160	F	20	2
0/200	G	40	5
0/300	H	50	5
0/400	I	50	5
0/600	K	100	10
0/1000	M	200	20
0/1500	N	200	20
0/2000	O	400	50
0/3000	P	500	50
0/5000	R	1000	100
0/10,000	U	1000	100
0/15,000	V	2000	200

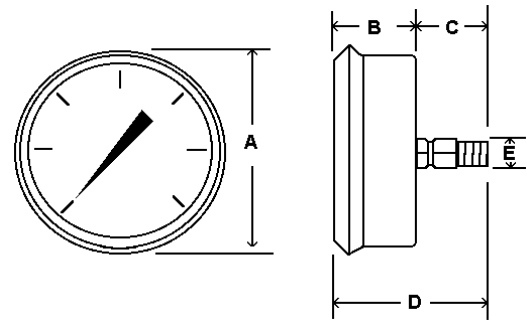

		A	B	C	D	E
1 ½" Dial	In	1.88	1.06	.89	1.95	1/8"
	MM	48	27	23	50	Npt
2" Dial	In	2.23	1.09	.71	1.99	1/8" or
	MM	57	28	23	51	1/4" npt
2 ½" Dial	In	2.80	1.28	1.18	2.46	1/4"
	MM	71	33	30	63	NPT
3 ½" Dial	In	3.83	1.14	1.08	2.20	1/4"
	MM	97	29	27	56	NPT
4" Dial	In	4.32	1.63	1.14	2.77	1/4"
	MM	110	42	29	71	NPT