

PRECISION INSTRUMENT COMPANY

PROCESS GAUGE MODEL '4501'

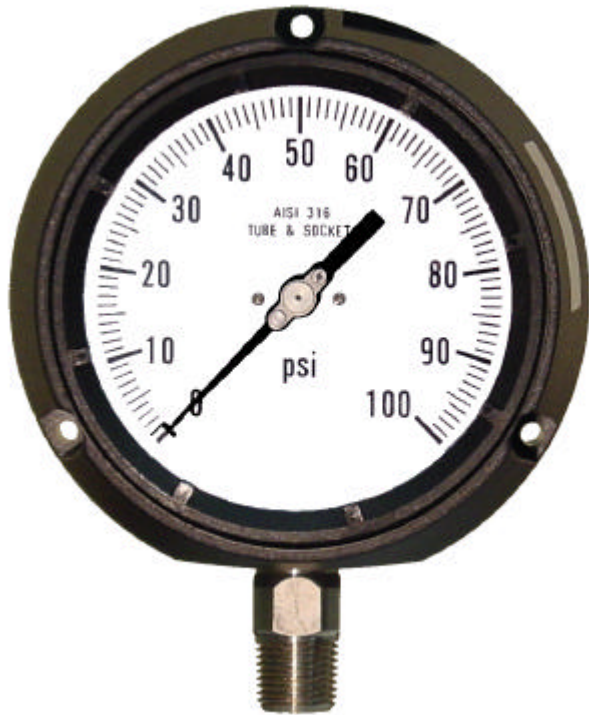

STANDARD SPECIFICATIONS:

DIAL: 4 1/2" Diameter

CASE: Phenolic-Solid Front/Blow-Out Back

LENS: Plastic With Gasket

POINTER: Knife Edge Micro-Adjustable

BOURDON TUBE: AISI 316 Stainless Steel

SOCKET : AISI 316 Stainless Steel

MOVEMENT: 304ss Heavy Duty Bushed

ACCURACY: 0.5 % Full Scale (Ansi Grade 2a)

STANDARD FEATURES

*Overload And Underload Stops

*Knife Blade Pointer For Precision Reading

*Hermetically Sealed/Weather Proof

*Liquid Fillable / No Kit Required

**Best Product Best Price Best Value !!*

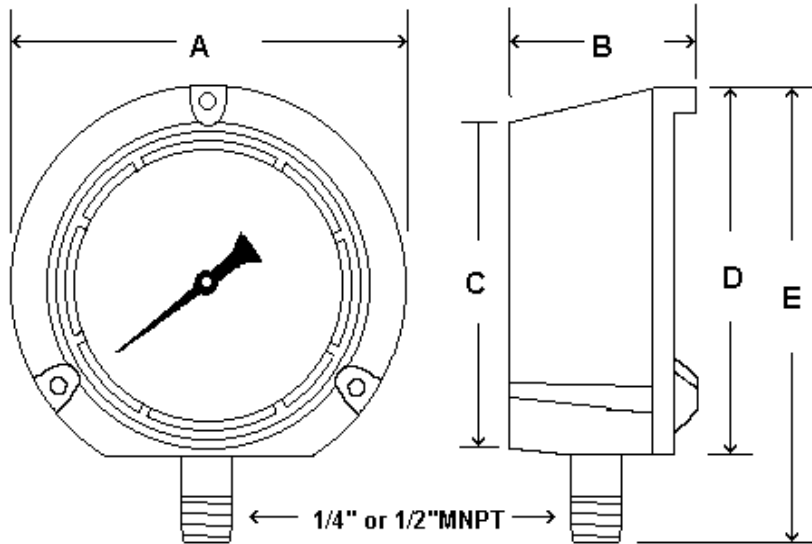

	A	B	C	D	E	NPT
INCH	5.81"	3.38"	5.06"	5.55"	6.98"	1/2" or
MM	148	86	129	141	177	1/4"

RANGE	FIGURES	MINOR
30"-0 hg vac	5"	0.2"
30"-0-15	10" & 5 psi	1" & 0.5 psi
30"-0-30	10" & 5 psi	1" & 0.5 psi
30"-0-60	10" & 10 psi	2" & 1 psi
30"-0-100	10" & 20 psi	2" & 1 psi
30"-0-150	10" & 30 psi	5" & 2 psi
30"-0-200	10" & 50 psi	5" & 2 psi
30"-0-300	10" & 50 psi	10" & 5 psi
30"-0-600	10" & 100 psi	10" & 10 psi
0-15 psi	3 psi	0.2 psi
0-30 psi	5 psi	0.2 psi
0-60 psi	5 psi	0.5 psi
0-100 psi	10 psi	1 psi
0-160 psi	20 psi	1 psi
0-200 psi	20 psi	2 psi
0-300 psi	50 psi	2 psi
0-400 psi	50 psi	2 psi
0-600 psi	50 psi	5 psi
0-800 psi	100 psi	5 psi
0-1000 psi	100 psi	10 psi
0-1500 psi	250 psi	10 psi
0-2000 psi	200 psi	20 psi
0-3000 psi	500 psi	20 psi
0-5000 psi	1,000 psi	50 psi
0-10,000 psi	1,000 psi	100 psi
0-15,000 psi	2,500 psi	100 psi
0-20,000 psi	2,000 psi	200 psi