

# PRECISION INSTRUMENT COMPANY

## 'CONTRACTOR' SERIES GAUGES

These Gauges Have Been Designed And Built With The Contractor In Mind. With A Price That Makes This The Most Attractive Gauge For Use On Any Project Where Bronze Internals Are Suitable For Use. Some Typical Applications Are; Air, Water, Gas, Oil And Steam\* (\* A Pigtail Siphon Should Always Be Used When Putting Any Gauge Into Steam Service).

### STANDARD FEATURES

- Stainless Steel Case  
(For Rust And Corrosion Resistance)
- Plastic Lens  
(To Resist Breakage & Won't Shatter)
- +/- 1 % Full Scale Accuracy
- Zero Adjust Screw On Dial  
(For Additional Fine Tuning)
- Large Easy To Read Numbers  
(On Single Scale Psi Only Dial)

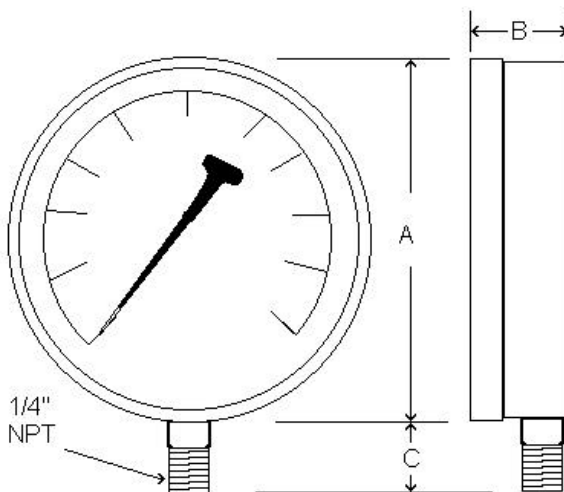
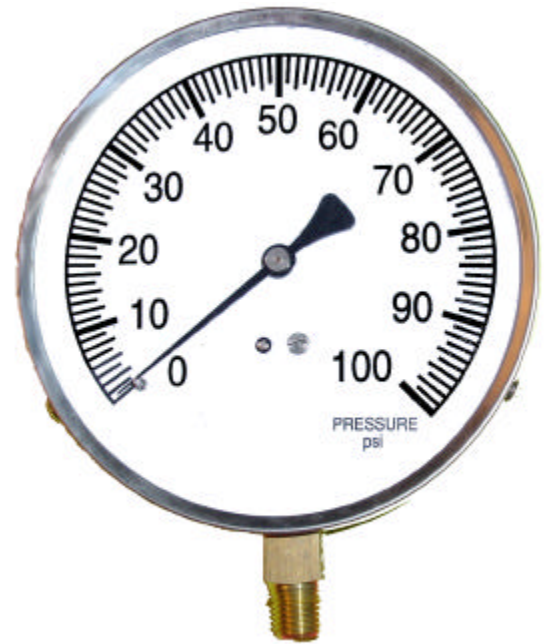

	A	B	C
INCHES	4.9"	1.17"	.97"
MM	124	30	25

PART NUMBER	RANGE	MAJOR	MINOR
CONTRACTOR-4LA	30" HG VAC	5" hg	2" hg
CONTRACTOR-4LCC	30/0/30	5 psi	1 psi
CONTRACTOR-4LCE	30/0/100	10 psi	1 psi
CONTRACTOR-4LCF	30/0/160	25 psi	2.5 psi
CONTRACTOR-4LB	0/15	2.5 psi	.25 psi
CONTRACTOR-4LC	0/30	5 psi	1 psi
CONTRACTOR-4LD	0/60	10 psi	1 psi
CONTRACTOR-4LE	0/100	10 psi	1 psi
CONTRACTOR-4LF	0/160	20 psi	2 psi
CONTRACTOR-4LG	0/200	20 psi	2 psi
CONTRACTOR-4LH	0/300	50 psi	5 psi
CONTRACTOR-4LJ	0/500	50 psi	5 psi

**Note:** all typical accessory type items such as gauge cocks, Pigtail/syphons, snubbers, needle valves or diaphragm seals can be Provided with gauges upon request.